

**FRONT ELEVATION**

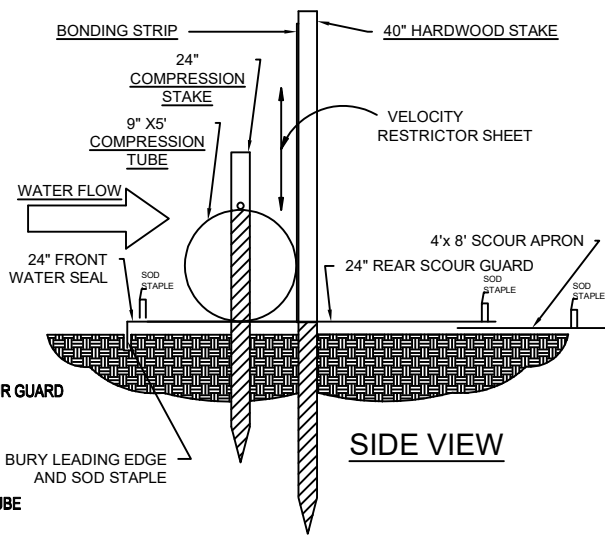
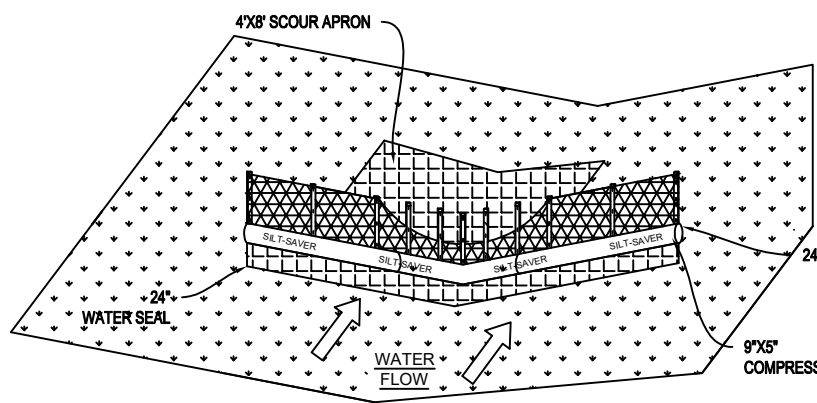

**SIDE VIEW**

**COMPONENTS INCLUDE:**

- VELOCITY RESTRICTOR SHEET PREFABRICATED WITH 1 3/8"x1 3/4" HARDWOOD / OAK POSTS (OR EQUAL DENSITY)
- ATTACHED FRONT WATER SEAL AND REAR SCOUR GUARD
- ADDITIONAL REAR SCOUR GUARD EXTENSION, 40 SOD STAPLES
- COMPRESSION TUBES FILLED WITH KILN DRIED PINE CHIPS (3) WITH COMPRESSION STAKES (6)

**MAINTENANCE**

ALL TEMPORARY EROSION, SEDIMENTATION, & POLLUTION CONTROL PRACTICES SHOULD BE INSPECTED DAILY. CONTRACTOR SHALL REMOVE SEDIMENT WHEN DEPOSITS REACH APPROXIMATELY ONE-HALF THE HEIGHT OF THE MATERIAL BARRIER. INSPECT DAILY FOR CUTS, ABRASIONS, AND PROPER INSTALLATION. REPLACE OR REPOSITION AS NECESSARY. REMOVE BUILDUP FROM HIGH VISIBILITY GREEN VELOCITY RESTRICTOR SHEET AS NEEDED BY TAPPING THE BACKSIDE WITH FLAT BOARD.

CITY DITCH CHECK  
 WITH 16" OVERFLOW  
 MODEL # HVDC14

FRAME MATERIAL: OAK/HARDWOOD
FILTER FABRIC MATERIAL: REFER TO SPEC
SCALE: NOT TO SCALE
LAST UPDATED: 2-12-2024