



\*\*\*\*Patent Pending\*\*\*\*

# SILT FENCE OUTLET

Pre-assembled Silt Fence Outlet  
Replaces Rock Outlets

A sediment barrier outlet designed to work with your perimeter protection to retain sediment and provide controlled stormwater release

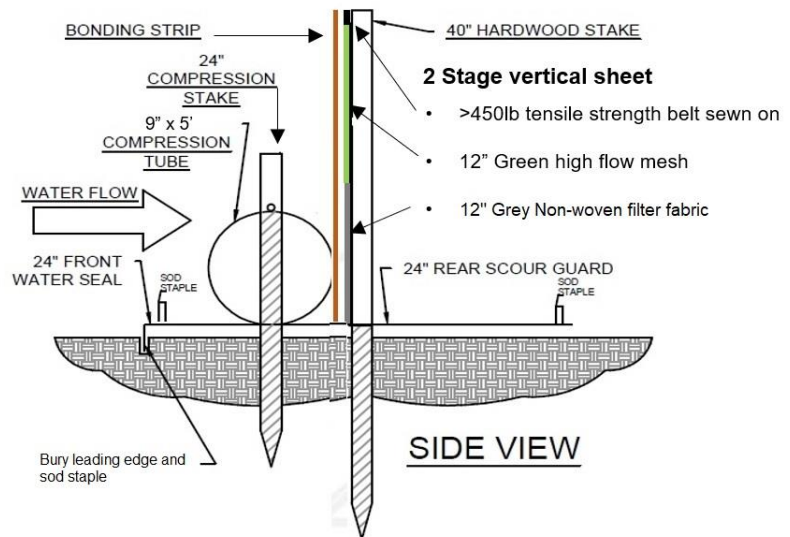

➤ Preassembled and sold as a kit to ensure quality control and consistency of installation. Includes:

- 2-Stage vertical sheet preassembled with posts on 2' centers (14-foot long)
- Attached front water seal and rear scour guard, with sod staples
- 3 compression tubes with 6 compression stakes
- 4 bonding strips

- The 2 Stage Outlet offers a dual-purpose design for greater sediment retention and controlled storm water release.
  - Stage 1 Non-woven filter fabric, closest to the ground, >96% filtration efficiency
  - Stage 2 High flow green mesh, >1100gpm/ft<sup>2</sup> controlled storm water release and filtration
- Attached front water seal and compression tubes filled with kiln dried wood chips and held in place with compression stakes prevent undermining while contributing to sediment impoundment and storm water control.
- Attached rear scour guard prevents scouring and undermining

PERIMETER PROTECTION - SILT FENCE OUTLET